

Low-Voltage Circuit Breakers

Selection Guide

*TemPower
TemBreak*



TERASAKI is always pleased to send you the world's top-class products.

Already for many decades TERASAKI has been internationally minded. This is proven by the number of certifications, authorizations and approvals by the world's leading organizations and authorities. TERASAKI maintains the top position. TERASAKI will exert its further efforts to attain more international quality recognition.



Certifications, Authorizations or Approvals by World's Leading Organizations

Air Circuit Breakers
ASTA/U.K. ASTA CERTIFICATION SERVICES
SECV/Australia State Electricity Commission Of Victoria
LR/U.K. Lloyd's Register of Shipping
BV/France Bureau Veritas
GL/Germany Germanischer Lloyd
AB/U.S.A. American Bureau of Shipping
NK/Japan Nippon Kaiji Kyokai

Moulded Case Circuit Breakers
ASTA/U.K. ASTA CERTIFICATION SERVICES
SECV/Australia State Electricity Commission Of Victoria
LR/U.K. Lloyd's Register of Shipping
BV/France Bureau Veritas
GL/Germany Germanischer Lloyd
AB/U.S.A. American Bureau of Shipping
NK/Japan Nippon Kaiji Kyokai

Based Standards

Air Circuit Breakers
IEC 60947-2 International Electrotechnical Commission
BS EN 60947 Part 2/U.K. British Standard
VDE 0660 Part 101/Germany Verband Deutscher Elektrotechniker
NEMA PUB NO. SG3/U.S.A. National Electrical Manufacturers Association
ANSI C37. 13/U.S.A. American National Standard Institute
JIS C8372/Japan Japanese Industrial Standard
JEC-160/Japan Japanese Electrical Committee

Moulded Case Circuit Breakers
IEC 60947-2 International Electrotechnical Commission
BS EN 60947 Part 2/U.K. British Standard
VDE 0660 Part 101/Germany Verband Deutscher Elektrotechniker
CEI EN 60947 Part 101/Germany Italian Standard
NEMA AB-1/U.S.A. National Electrical Manufacturers Association
JIS C8370/Japan Japanese Industrial Standard

Short-circuit Testing Station

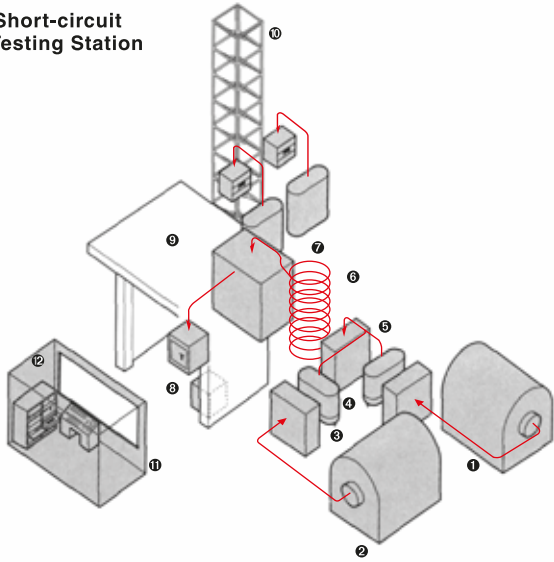

- ① Short-circuit test generator No.1
- ② Short-circuit test generator No. 2
- ③ Voltage change device
- ④ Back-up breaker
- ⑤ Making switch
- ⑥ Reactors, Resistance
- ⑦ Step-down 3ø transformer
- ⑧ 800V d.c. short-circuit testing equipment
- ⑨ Pit
- ⑩ Impulse generator
- ⑪ Control room
- ⑫ Computerized control equipment

Combined Short-circuit Capacity (MVA) When Two Short-circuit Test Generators (No.1 and No.2) are Paralleled.

Time after short-circuit (Cycle)	Sym. 3ø R.M.S.
0	1060
1/2	950
1	860
3	710



Short-circuit test generator No.1



Short-circuit test generator No.2

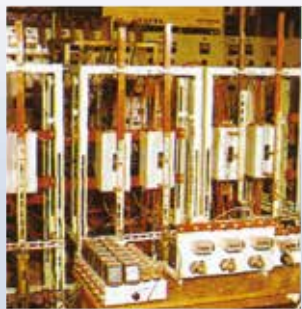

TYPE TESTS on every lot

- ★ Construction test
- ★ Operation test
- ★ Tripping test
- ★ Overload test
- ★ Overshooting test
- ★ Temperature rise test
- ★ Endurance test
- ★ Insulation resistance test
- ★ Withstand voltage test
- ★ Short-circuit test
- ★ Flexible cord protection test
- ★ Short-circuit making capacity test
- ★ Short-time withstand current test



RELIABILITY TESTS

- ★ Vibration test
- ★ Mechanical operation test
- ★ Rust proof test
- ★ Mechanical impact test
- ★ Heat-shock test
- ★ Gas proof test
- ★ Aging test

Air Circuit Breakers

AR Standard Series

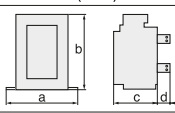
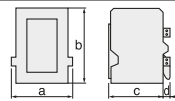
Series		Standard	Standard	High fault	Standard	High fault	High fault	Standard	High fault
AMPERE RATING(A)		800	1250	1250	1600	1600	1600	2000	2000
TYPE		AR208S	AR212S	AR212H	AR216S	AR216H	AR316H	AR220S	AR220H
RATED CURRENT (max) [I_n](A)	JIS ^⑫ , IEC, EN, AS ① ② NEMA, ANSI Marine	800	1250	1250	1600	1600	1600	2000	2000
NEUTRAL POLE AMPERES FRAME (A)		800	1250	1250	1600	1600	1600	2000	2000
NUMBER OF POLES	③ ④	3 4	3 4	3 4	3 4	3 4	3 4	3 4	3 4
RATED PRIMARY CURRENT OF OVER-CURRENT RELEASE [I_{CT}](A)		200	400	200	400	1600	200	400	2000
• for general feeder circuit use		400	800	400	800		400	800	
		800	1250	800	1250		800	1250	
				1250	1600		1250	1600	
							1600	2000	
RATED CURRENT OF OVER-CURRENT RELEASE (A)		100 ≤ I_n ≤ 200	200 ≤ I_n ≤ 400	100 ≤ I_n ≤ 200	200 ≤ I_n ≤ 400	800 ≤ I_n ≤ 1600	100 ≤ I_n ≤ 200	200 ≤ I_n ≤ 400	1000 ≤ I_n ≤ 2000
• for generator protection use		200 < I_n ≤ 400	400 < I_n ≤ 800	200 < I_n ≤ 400	400 < I_n ≤ 800		200 < I_n ≤ 400	400 < I_n ≤ 800	
[I_n] is generator rated current.		400 < I_n ≤ 800	630 < I_n ≤ 1250	400 < I_n ≤ 800	630 < I_n ≤ 1250		400 < I_n ≤ 800	630 < I_n ≤ 1250	
				630 < I_n ≤ 1250	800 < I_n ≤ 1600		630 < I_n ≤ 1250	800 < I_n ≤ 1600	
							800 < I_n ≤ 1600	1000 < I_n ≤ 2000	
AC RATED INSULATION VOLTAGE [U_i](V. 50/60Hz)		1000	1000	1000	1000	1000	1000	1000	1000
RATED OPERATIONAL VOLTAGE [U_g](V. 50/60Hz)		690	690	690	690	690	690	690	690
AC RATED BREAKING CAP [kA sym rms]/MAKING CAP [kA peak]									
JIS ^⑫ , IEC, EN, AS	AC 690V ⑤	50/105	50/105	55/121	50/105	55/121	85/187	50/105	55/121
[I_{CS} = I_{CU}]	440V	65/143 ⑥	65/143 ⑥	80/176	65/143 ⑥	80/176	100/220	65/143 ⑥	80/176
NEMA	AC 600V	42/96.6	42/96.6	42/96.6	42/96.6	42/96.6	50/115	42/96.6	42/96.6
ANSI	480V	50/115	50/115	55/127	50/115	55/127	80/184	50/115	55/127
	240V	65/149.5	65/149.5	80/184	65/149.5	80/184	100/230	65/149.5	80/184
	⑦	DC 600V ⑧	40/40	40/40	40/40	40/40	40/40	40/40	40/40
		250V	40/40	40/40	40/40	40/40	40/40	40/40	40/40
NK ⑨	AC 690V	50/115	50/115	55/128	50/115	55/128	85/201	50/115	55/128
	450V	65/153 ⑥	65/153 ⑥	80/186	65/153 ⑥	80/186	100/233	65/153 ⑥	80/186
LR, AB, ⑨	AC 690V	50/115	50/115	55/128	50/115	55/128	85/201	50/115	55/128
GL, BV	450V	65/153 ⑥	65/153 ⑥	80/186	65/153 ⑥	80/186	100/233	65/153 ⑥	80/186
RATED IMPULSE WITHSTAND VOLTAGE [U_{imp}](kV)		12	12	12	12	12	12	12	12
RATED SHORT TIME WITHSTAND	1s	65	65	80	65	80	100	65	80
CURRENT [I_{cw}](kA rms)	3s	50	50	55	50	55	75	50	55
LATCHING CURRENT (kA)		65	65	65	65	65	85	65	65
TOTAL BREAKING TIME (s)		0.03	0.03	0.03	0.03	0.03	0.03	0.03	0.03
CLOSING OPERATION TIME									
SPRING CHARGING TIME (s) max.		10	10	10	10	10	10	10	10
CLOSE TIME (s) max.		0.08	0.08	0.08	0.08	0.08	0.08	0.08	0.08
No. of operating cycles									
Mechanical life	with maintenance	30000	30000	30000	30000	30000	25000	25000	30000
	without maintenance	15000	15000	15000	15000	15000	12000	12000	15000
Electrical life	without maintenance AC460V	12000	12000	12000	12000	12000	10000	10000	12000
	AC690V	10000	10000	10000	10000	10000	7000	7000	10000
Draw-Out Body (kg)	⑪	45 51	45 51	46 52	46 52	46 52	56 68	46 52	46 52
Draw-Out Chassis (kg)	⑪	28 35	28 35	33 42	30 38	33 42	49 57	33 42	33 42
Total Draw-Out Weight (kg)	⑪	73 86	73 86	79 94	76 90	79 94	105 125	79 94	79 94
Fixed (kg)	⑪	53 59	53 59	54 60	54 60	54 60	80 92	54 60	54 60
OUTLINE DIMENSION (mm)									
FIXED TYPE		a 360, b 445, c 460, d 290, e 75	a 360, b 445, c 460, d 290, e 75	a 360, b 445, c 460, d 290, e 75	a 360, b 445, c 460, d 290, e 75	a 360, b 445, c 460, d 290, e 75	a 466, b 586, c 460, d 290, e 75	a 360, b 445, c 460, d 290, e 75	a 360, b 445, c 460, d 290, e 75
DRAW-OUT TYPE ⑩		a 354, b 439, c 460, d 345, e 40	a 354, b 439, c 460, d 345, e 40	a 354, b 439, c 460, d 345, e 40	a 354, b 439, c 460, d 345, e 40	a 354, b 439, c 460, d 345, e 40	a 460, b 580, c 460, d 345, e 40	a 354, b 439, c 460, d 345, e 40	a 354, b 439, c 460, d 345, e 40

①: Values in open air at 40°C (45°C for marine applications).
 ②: Values of AR208S, AR212S, AR216S for draw-out type with horizontal terminals, Values of the other ACBs for draw-out type with vertical terminals.
 ③: For 2 pole ACBs use outside poles of 3 pole ACB.
 ④: 4poles ACBs without Neutral phases protection can not apply IT earthing system.
 ⑤: Contact TERASAKI for the details.
 ⑥: For 500V AC.
 ⑦: Please contact TERASAKI for DC application.
 ⑧: 3 poles in series should be applied for 600V DC.
 ⑨: Applicable to only 3 pole ACBs.
 ⑩: For vertical terminals or horizontal terminals.
 ⑪: These weights are based on normal specifications with the OCR and standard accessories.
 ⑫: Comply with JIS C 8201-2-1 Ann.1 Ann.2
 ⑬: Being or will be applied.
 ⑭: Values for ACBs with INST. 100/220kA for ACBs with MCR.
 *: Contact TERASAKI for the ratings.
Note: When the INST trip function is set to NON, the MCR function should be enabled, otherwise, the rated breaking capacity is reduced to the rated latching current.

Air Circuit Breakers

AR Standard Series

Series		High fault	High fault	Standard	High fault	Standard	High fault	Standard	Standard
AMPERE RATING(A)		2000	2000	2500	2500	3200	3200	4000	4000
TYPE		AR320H	AR420H	AR325S	AR325H	AR332S	AR332H	AR440SB	AR440S
RATED CURRENT (max) [I_n](A)	JIS ^⑫ , IEC, EN, AS ① ② NEMA, ANSI Marine	2000	2000	2500	2500	3200	3200	4000	4000
NEUTRAL POLE AMPERES FRAME (A)		2000	2000	2500	2500	3200	3200	4000	4000
NUMBER OF POLES	③ ④	3 4	3	3 4	3 4	3 4	3 4	3 4	3 4
RATED PRIMARY CURRENT OF OVER-CURRENT RELEASE [I_{CT}](A)		2000	800	2500	2500	3200	3200	4000	4000
• for general feeder circuit use									
RATED CURRENT OF OVER-CURRENT RELEASE (I_{CT})(A)		$1000 \leq I_n \leq 2000$	$400 \leq I_n \leq 800$ $1000 \leq I_n \leq 2000$	$1250 \leq I_n \leq 2500$	$1250 \leq I_n \leq 2500$	$1600 \leq I_n \leq 3200$	$1600 \leq I_n \leq 3200$	$2000 \leq I_n \leq 4000$	$2000 \leq I_n \leq 4000$
• for generator protection use [I_n] is generator rated current.									
AC RATED INSULATION VOLTAGE [U_i](V, 50/60Hz)		1000	1000	1000	1000	1000	1000	1000	1000
RATED OPERATIONAL VOLTAGE [U_g](V, 50/60Hz)		690	690	690	690	690	690	690	690
AC RATED BREAKING CAP [kA sym rms]/MAKING CAP [kA peak]									
JIS ^⑫ , IEC, EN, AS	AC 690V ⑤	85/187	75/165	65/143	85/187	65/143	85/187	85/187	75/165
[$I_{cs} = I_{cu}$]	440V	100/220	120/264 ⑭	85/187 ⑥	100/220	85/187 ⑥	100/220	100/220	100/220
NEMA	AC 600V	50/115	65/149.5	50/115	50/115	50/115	50/115	50/115	65/149.5
ANSI	480V	80/184	75/172.5	65/149.5	80/184	65/149.5	80/184	80/184	75/172.5
	240V	100/230	120/276	85/195.5	100/230	85/195.5	100/230	100/230	100/230
	⑦	DC 600V ⑧	40/40	40/40	40/40	40/40	40/40	40/40	40/40
		250V	40/40	40/40	40/40	40/40	40/40	40/40	40/40
NK	⑨	AC 690V	85/201	⑬	65/153	85/201	65/153	85/201	⑬
		450V	100/233	⑬	85/201 ⑥	100/233	85/201 ⑥	100/233	⑬
LR, AB,	⑨	AC 690V	85/201	⑬	65/153	85/201	65/153	85/201	⑬
GL, BV		450V	100/233	⑬	85/201 ⑥	100/233	85/201 ⑥	100/233	⑬
RATED IMPULSE WITHSTAND VOLTAGE [U_{imp}](kV)		12	12	12	12	12	12	12	12
RATED SHORT TIME WITHSTAND	1s	100	100	85	100	85	100	100	100
CURRENT [I_{cw}](kA rms)	3s	75	85	65	75	65	75	75	85
LATCHING CURRENT (kA)		85	100	85	85	85	85	85	100
TOTAL BREAKING TIME (s)		0.03	0.03	0.03	0.03	0.03	0.03	0.03	0.03
CLOSING OPERATION TIME									
SPRING CHARGING TIME (s) max.		10	10	10	10	10	10	10	10
CLOSE TIME (s) max.		0.08	0.08	0.08	0.08	0.08	0.08	0.08	0.08
No. of operating cycles									
Mechanical life	with maintenance	25000	15000	20000	20000	20000	20000	15000	15000
	without maintenance	12000	8000	10000	10000	10000	10000	8000	8000
Electrical life	without maintenance AC460V	10000	3000	7000	7000	7000	7000	3000	3000
	AC690V	7000	2500	5000	5000	5000	5000	2500	2500
Draw-Out Body (kg)	⑪	56 68	71	56 68	56 68	56 68	56 68	58 71	71 92
Draw-Out Chassis (kg)	⑪	49 57	76	49 57	49 57	49 57	49 57	68 87	68 84
Total Draw-Out Weight (kg)	⑪	105 125	147	105 125	105 125	105 125	105 125	126 158	139 176
Fixed (kg)	⑪	80 92	—	80 92	80 92	80 92	80 92	— —	— —
OUTLINE DIMENSION (mm)									
FIXED TYPE		a	466 586	—	466 586	466 586	466 586	466 586	— —
		b	460	—	460	460	460	—	—
		c	290	—	290	290	290	—	—
		d	75	—	75	75	75	—	—
DRAW-OUT TYPE ⑩		a	460 580	631	460 580	460 580	460 580	460 580	631 801
		b	460	460	460	460	460	460	460
		c	345	375	345	345	345	345	375
		d	40	53	40	40	40	140	53

①: Values in open air at 40°C (45°C for marine applications).
 ②: Values of AR208S, AR212S, AR216S for draw-out type with horizontal terminals, Values of the other ACBs for draw-out type with vertical terminals.
 ③: For 2 pole ACBs use outside poles of 3 pole ACB.
 ④: 4poles ACBs without Neutral phases protection can not apply IT earthing system.
 ⑤: Contact TERASAKI for the details.
 ⑥: For 500V AC.
 ⑦: Please contact TERASAKI for DC application.
 ⑧: 3 poles in series should be applied for 600V DC.
 ⑨: Appl able to only pole ACBs.
 ⑩: For vertical terminals or horizontal terminals.
 ⑪: These weights are based on normal specifications with the OCR and standard accessories.
 ⑫: Comply with JIS C 8201-2-1 Ann.1 Ann.2
 ⑬: Being or will be applied.
 ⑭: Values for ACBs with INST. 100/220kA for ACBs with MCR.
 ※: Contact TERASAKI for the ratings.
Note: When the INST trip function is set to NON, the MCR function should be enabled, otherwise, the rated breaking capacity is reduced to the rated latching current.

Air Circuit Breakers

AR Standard Series

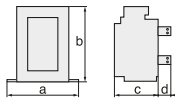
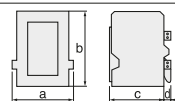
Series	High fault	Standard	Standard	High fault					
AMPERE RATING(A)	4000	5000	6300	6300					
TYPE	AR440H	AR650S	AR663S	AR663H					
RATED CURRENT (max) [I_n](A)	4000	5000	6300	6300					
① ②	JIS ^⑫ , IEC, EN, AS NEMA, ANSI Marine								
NEUTRAL POLE AMPERES FRAME (A)	4000	5000	6300	6300					
NUMBER OF POLES	3 ④	3 ④	3 ④	3 ④					
RATED PRIMARY CURRENT OF OVER-CURRENT RELEASE [I_{CT}](A)	4000	5000	6300	5000 6300					
• for general feeder circuit use									
RATED CURRENT OF OVER-CURRENT RELEASE (I_{OC})	$2000 \leq I_n \leq 4000$	$2500 \leq I_n \leq 5000$	$3150 \leq I_n \leq 6300$	$2500 \leq I_n \leq 5000$ $3150 \leq I_n \leq 6300$					
• for generator protection use [I_n] is generator rated current.									
AC RATED INSULATION VOLTAGE [U_i](V. 50/60Hz)	1000	1000	1000	1000					
RATED OPERATIONAL VOLTAGE [U_e](V. 50/60Hz)	690	690	690	690					
AC RATED BREAKING CAP [kA sym rms]/MAKING CAP [kA peak]									
JIS ^⑫ , IEC, EN, AS	AC 690V ^⑤	75/165	85/187	85/187	85/187				
[$I_{cs} = I_{cu}$]	440V	120/264 ^⑭	120/264	120/264	135/297				
NEMA	AC 600V	65/149.5	65/149.5	65/149.5	65/149.5				
ANSI	480V	75/172.5	80/184	80/184	80/184				
	240V	120/276	100/230	100/230	100/230				
⑦	DC 600V ^⑧	40/40	40/40	40/40	40/40				
	250V	40/40	40/40	40/40	40/40				
NK ^⑨	AC 690V	^⑬	85/201 ^⑬	85/201 ^⑬	85/201 ^⑬				
	450V	^⑬	120/287 ^⑬	120/287 ^⑬	138/322 ^⑬				
LR, AB, ^⑨	AC 690V	^⑬	85/201 ^⑬	85/201 ^⑬	85/201 ^⑬				
GL, BV	450V	^⑬	120/287 ^⑬	120/287 ^⑬	138/322 ^⑬				
RATED IMPULSE WITHSTAND VOLTAGE [U_{imp}](kV)	12	12	12	12					
RATED SHORT TIME WITHSTAND	1s	100	120	120	135				
CURRENT [I_{cw}](kA rms)	3s	85	85	85	85				
LATCHING CURRENT (kA)		100	120	120	120				
TOTAL BREAKING TIME (s)		0.03	0.05	0.05	0.05				
CLOSING OPERATION TIME									
SPRING CHARGING TIME (s) max.		10	10	10	10				
CLOSE TIME (s) max.		0.08	0.08	0.08	0.08				
No. of operating cycles									
Mechanical life with maintenance		15000	10000	10000	10000				
without maintenance		8000	5000	5000	5000				
Electrical life without maintenance AC460V		3000	1000	1000	1000				
AC690V		2500	500	500	500				
Draw-Out Body (kg)	⑪	71	125 160	140 180	140 180				
Draw-Out Chassis (kg)	⑪	76	75 100	80 105	80 105				
Total Draw-Out Weight (kg)	⑪	147	200 260	220 285	220 285				
Fixed (kg)	⑪	—	—	—	—				
OUTLINE DIMENSION (mm)									
FIXED TYPE		a	—	—	—	—			
		b	—	—	—	—			
		c	—	—	—	—			
		d	—	—	—	—			
DRAW-OUT TYPE ^⑩		a	631	799 1034	799 1034	799 1034			
		b	460	460	460	460			
		c	375	380	380	380			
		d	53	60	60	60			

①: Values in open air at 40°C (45°C for marine applications).
 ②: Values of AR208S, AR212S, AR216S for draw-out type with horizontal terminals, Values of the other ACBs for draw-out type with vertical terminals.
 ③: For 2 pole ACBs use outside poles of 3 pole ACB.
 ④: 4poles ACBs without Neutral phases protection can not apply IT earthing system.
 ⑤: Contact TERASAKI for the details.
 ⑥: For 500V AC.
 ⑦: Please contact TERASAKI for DC application.
 ⑧: 3 poles in series should be applied for 600V DC.

⑨: Appl able to only pole ACBs.
 ⑩: For vertical terminals or horizontal terminals.
 ⑪: These weights are based on normal specifications with the OCR and standard accessories.
 ⑫: Comply with JIS C 8201-2-1 Ann.1 Ann.2
 ⑬: Being or will be applied.
 ⑭: Values for ACBs with INST. 100/220kA for ACBs with MCR.
 ※: Contact TERASAKI for the ratings.
Note: When the INST trip function is set to NON, the MCR function should be enabled, otherwise, the rated breaking capacity is reduced to the rated latching current.

Moulded Case Circuit Breakers (New Compact Breakers)

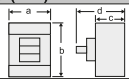
Frame Size [A]	100	125	160	160	160	250	250
Type	E100SF	S125-SF	E160-SF	S160SCF	S160SF	E250SF	S250SF
Number of Poles	2 3	2 3 4	2 3 4	2 3 4	2 3 4	3 4	3 4
■ RATED CURRENT (In) [A] at 40°C (45°C for marine applications)	10 30 60 15 40 75 20 50 100	15 40 75 20 50 100 30 60 125	15 40 75 20 50 100 30 60 125 160	15 40 75 20 50 100 30 60 125 160	15 40 75 20 50 100 30 60 125 160	125 225 150 250 175 200	125 225 150 250 175 200
Rated impulse withstand voltage (Uimp) [kV]	6	8	8	8	8	8	8
Rated insulation voltage (Ui) [VAC]	690	690	690	690	690	690	690
■ AC RATED BREAKING CAPACITY [kA sym. rms.]	7.5	—	—	—	—	—	—
JIS C 8370	550V 450V 220V	—	—	—	—	—	—
IEC 60947-2	690V	—	—	—	—	—	—
EN 60947-2	500V 440V 415V 380V 240V	7.5/3.8 10/5 16/8 25/13	12/6 25/13 30/15 50/25	6/3 10/5 16/8 25/13	7.5/4 15/7.5 25/13 35/18	6/3 10/7.5 25/13 50/25	4/2 25/13 30/15 85/43
■ DC RATED BREAKING CAPACITY [kA] ①	250V 125V	7.5/3.8 15/7.5	25/13 40/20	13/7 20/10	20/10 30/15	25/13 40/20	25/13 40/20
Rated short time current (Icw) [kA. rms.]	—	—	—	—	—	—	—
Protection	—	—	—	—	—	—	—
Adjustable thermal, adjustable magnetic	—	—	—	—	—	—	—
Fixed thermal, fixed magnetic	■	■	■	■	■	■	■
Microprocessor	—	—	—	—	—	—	—
Utilization Category	A	A	A	A	A	A	A
■ DIMENSIONS (mm)	50 75	50 75 100	50 75 100	50 75 100	50 75 100	105 140	105 140
	a b c d	130 130 68 87	130 130 68 95	130 130 68 95	130 130 68 95	165 165 68 95	165 165 68 95
Weight (kg) (standard type)	0.48 0.74	0.6 0.8 1.0	0.6 0.8 1.0	0.6 0.8 1.0	0.6 0.8 1.0	1.5 1.9	1.5 1.9

Marine

Moulded Case Circuit Breakers

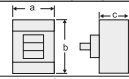
Frame Size (A)	100	125	100	125	125	100	125
Type	S100NF	S125NF	S100GF	S125GF	S125RF	H100NF	H125NF
Number of Poles	2 3 4	2 3 4	2 3 4	2 3 4	3 4	3 4	3 4
■ RATED CURRENT (In) [A] at 40°C (45°C for marine applications)	15 50 20 60 30 75 40 100	125	15 50 20 60 30 75 40 100	125	15 50 20 60 30 75 40 100 125	15 50 20 60 30 75 40 100	15 50 20 60 30 75 40 100
Rated impulse withstand voltage Uimp [kV]	8	8	8	8	8	8	8
AC rated insulation voltage (Ui) [VAC]	690	690	690	690	690	690	690
■ AC RATED BREAKING CAPACITY sym. r.m.s. [kA]	—	—	—	—	—	—	—
JIS C 8370	550V 460V 220V	—	—	—	—	65 100	—
IEC 60947-2	690V	6/6	6/6	6/6	6/6	20/15	20/15
EN 60947-2	500V 440V 415V 380V 240V	22/22 25/25 30/30 30/30 50/50	22/22 25/25 30/30 30/30 50/50	25/22 50/25 65/33 65/33 85/85	25/22 50/25 65/33 65/33 85/85	35/35 65/65 65/65 65/65 100/100	45/45 120/80 125/85 125/85 150/150
■ DC RATED BREAKING CAPACITY [kA]	250V 125V	40/30	25/19 40/30	40/40 40/40	40/40 40/40	40/40 40/40	40/40 40/40
Rated short time current r.m.s. [kA] [Icw]	—	—	—	—	—	—	—
Protection	—	—	—	—	—	—	—
Adjustable thermal, adjustable magnetic	—	—	—	—	—	—	—
Fixed thermal, adjustable magnetic	—	—	—	—	—	—	—
Fixed thermal, fixed magnetic	■	■	■	■	■	■	■
Microprocessor	—	—	—	—	—	—	—
Utilization Category	A	A	A	A	A	A	A
■ OUTLINE DIMENSIONS (mm)	60 90 120	60 90 120	60 90 120	60 90 120	105 140	105 140	105 140
	a b c	155 68	155 68	155 68	165 107	165 103	165 103
Weight (kg) (standard type)	0.7 1.1 1.4	0.7 1.1 1.4	0.7 1.1 1.4	0.7 1.1 1.4	2.4 3.2	2.4 3.2	2.4 3.2

Note: DC rating available on request.

Moulded Case Circuit Breakers

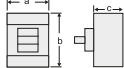
Frame Size (A)	100	125	225	250	225	250	225
Type	L100NF	L125NF	S225NF	S250NF	S225GF	S250GF	S225RF
Number of Poles	3 4	3 4	3 4	3 4	3 4	3 4	3 4
■ RATED CURRENT (In) [A] at 40°C (45°C for marine applications)	15 50 20 60 30 75 40 100	125	125 200 150 225 175	250	125 200 150 225 175	250	125 200 150 225 175
Rated impulse withstand voltage Uimp [kV]	8	8	8	8	8	8	8
AC rated insulation voltage (Ui) [VAC]	690	690	690	690	690	690	690
■ AC RATED BREAKING CAPACITY sym. r.m.s. [kA]	—	—	—	—	—	—	—
JIS C 8370	550V 460V 220V	—	—	—	—	—	—
IEC 60947-2	690V	25/20	7.5/7.5	7.5/7.5	7.5/7.5	7.5/7.5	20/15
EN 60947-2	500V 440V 415V 380V 240V	65/65 180/135 200/150 200/150 40/40	65/65 180/135 25/25 200/150 35/35 40/40	25/25 25/25 35/35 35/35 65/65 40/40	25/25 25/25 35/35 35/35 65/35 40/40	25/25 50/25 65/35 65/35 85/85 40/40	25/25 65/65 65/65 65/65 100/100 40/40
■ DC RATED BREAKING CAPACITY [kA]	250V 125V	40/40	40/40	40/40	40/40	40/40	40/40
Rated short time current r.m.s. [kA] [Icw]	—	—	—	—	—	—	—
Protection	—	—	—	—	—	—	—
Adjustable thermal, adjustable magnetic	—	—	—	—	—	—	—
Fixed thermal, adjustable magnetic	—	—	—	—	—	—	—
Fixed thermal, fixed magnetic	■	■	■	■	■	■	■
Microprocessor	—	—	—	—	—	—	—
Utilization Category	A	A	A	A	A	A	A
■ OUTLINE DIMENSIONS (mm)							
	a 105 140 b 165 c 103	a 105 140 b 165 c 103	a 105 140 b 165 c 68	a 105 140 b 165 c 68	a 105 140 b 165 c 68	a 105 140 b 165 c 68	a 105 140 b 165 c 107
Weight (kg) (standard type)	2.4 3.2	2.4 3.2	1.5 1.9	1.5 1.9	1.5 1.9	1.5 1.9	2.4 3.2

Moulded Case Circuit Breakers

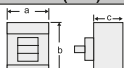
Frame Size (A)	225	250	225	250	400	400	400
Type	H225NF	H250NF	L225NF	L250NF	S400CF	S400NF	S400GF
Number of Poles	3 4	3 4	3 4	3 4	3 4	3 4	3 4
■ RATED CURRENT (In) [A] at 40°C (45°C for marine applications)	125 225 150 175 200	250	125 225 150 175 200	250	125 225 400 150 250 175 300 200 350	125 225 400 150 250 175 300 200 350	125 225 400 150 250 175 300 200 350
Rated impulse withstand voltage Uimp [kV]	8	8	8	8	8	8	8
AC rated insulation voltage (Ui) [VAC]	690	690	690	690	690	690	690
■ AC RATED BREAKING CAPACITY sym. r.m.s. [kA]	—	—	—	—	—	—	—
JIS C 8370	550V 460V 220V	—	—	—	—	—	—
IEC 60947-2	690V	20/15	25/20	25/20	15/15	20/15	20/15
EN 60947-2	500V 440V 415V 380V 240V	45/45 120/80 125/85 125/85 150/150	45/45 120/80 125/85 125/85 150/150	65/65 180/135 200/150 200/150 200/150	36/36 36/36 36/36 50/50 40/40	30/30 45/45 50/50 50/50 85/85	30/30 65/50 70/50 70/50 100/85
■ DC RATED BREAKING CAPACITY [kA]	250V 125V	40/40	40/40	40/40	40/40	40/40	40/40
Rated short time current r.m.s. [kA] [Icw]	—	—	—	—	—	—	—
Protection	—	—	—	—	—	—	—
Adjustable thermal, adjustable magnetic	—	—	—	—	—	—	—
Fixed thermal, adjustable magnetic	—	—	—	—	—	—	—
Fixed thermal, fixed magnetic	■	■	■	■	■	■	■
Microprocessor	—	—	—	—	—	—	—
Utilization Category	A	A	A	A	A	A	A
■ OUTLINE DIMENSIONS (mm)							
	a 105 140 b 165 c 103	a 105 140 b 165 c 103	a 105 140 b 165 c 103	a 105 140 b 165 c 103	a 140 185 b 260 c 103	a 140 185 b 260 c 103	a 140 185 b 260 c 103
Weight (kg) (standard type)	2.4 3.2	2.4 3.2	2.4 3.2	2.4 3.2	4.2 5.6	4.2 5.6	4.2 5.6

Note: DC rating available on request.

Moulded Case Circuit Breakers

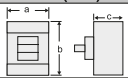
Frame Size (A)	400	800	800				
Type	S400PF	S800NF	S800RF				
Number of Poles	3 4	3 4	3 4				
RATED CURRENT (In) [A] at 40°C (45°C for marine applications)	250 400 300 350	500 700 630 800	500 700 630 800				
Rated impulse withstand voltage Uimp [kV]	8	8	8				
AC rated insulation voltage (Ui) [VAC]	690	690	690				
AC RATED BREAKING CAPACITY sym. r.m.s. [kA]							
JIS C 8370	550V 460V 220V						
IEC 60947-2	690V	20/15 30/30	20/20 30/30	25/20 45/34			
EN 60947-2	500V 440V 415V 380V 240V	80/80 85/85 85/85	45/45 50/50 50/50	65/50 70/50 100/75			
DC RATED BREAKING CAPACITY [kA]	250V 125V	40/40 40/40	50/50 50/50	50/50 50/50			
Rated short time current r.m.s. [kA] [Icw]							
Protection							
Adjustable thermal, adjustable magnetic							
Fixed thermal, adjustable magnetic	■	■	■				
Fixed thermal, fixed magnetic							
Microprocessor							
Utilization Category	A	A	A				
OUTLINE DIMENSIONS (mm)							
	a: 140 185 b: 260 c: 103	210 280 273 103	210 280 273 103				
Weight (kg) (standard type)	4.2 5.6	8.5 11.5	8.5 11.5				

Moulded Case Circuit Breakers

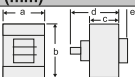
Frame Size [A]	125	125	125	125	250	250	250	250	400
Type	S125NJ	S125GJ	S125RJ	H125NJ	S250NJ	S250GJ	S250RJ	H250NJ	S400CJ
Number of Poles	3 4	3 4	3 4	3 4	3 4	3 4	3 4	3 4	3 4
Utilization Category	A	A	A	A	A	A	A	A	A
RATED CURRENT (In) [A] at 45°C	20 100 32 125 50 63	20 100 32 125 50 63	20 100 32 125 50 63	20 100 32 125 50 63	160 200 250	160 200 250	160 250	160 250	250 400
Rated insulation voltage (Ui) [VAC]	800	800	800	800	800	800	800	800	800
AC RATED BREAKING CAPACITY [kA sym. rms.]									
JIS C 8370	525V 440V 220V	22 25 50	25 50 85	35 65 100	45 120 150	25 25 65	25 50 85	35 65 100	45 120 150
IEC 60947-2	690V	6/6	6/6	20	20/15	7.5/7.5	7.5/7.5	20	20/15
EN 60947-2	525V 440V 415V	22/22 25/25	25/22 50/25	35/35 65/65	45/45 120/80	25/25 25/25	25/25 50/25	35/35 65/65	45/45 120/80
DC RATED BREAKING CAPACITY [kA] ①	240V 250V	50/50 25	85/85 40	100/100 40	150/150 40	65/65 40	85/85 40	100/100 40	150/150 40
Rated impulse withstand voltage (Uimp) [kV]	8	8	8	8	8	8	8	8	8
Protection	■	■	■	■	■	■	■	■	■
Adjustable thermal, adjustable magnetic									
Fixed thermal, fixed magnetic									
Microprocessor									
Rated short time current (Icw) [kA rms.]									
Utilization Category	A	A	A	A	A	A	A	A	A
DIMENSIONS (mm)									
	a: 90 120 b: 155 c: 68	90 120 155 68	105 140 165 103	105 140 165 103	105 140 165 68	105 140 165 68	105 140 165 103	105 140 165 103	140 185 260 103
Weight (kg) (standard type)	1.1 1.4	1.1 1.4	2.4 3.2	2.4 3.2	1.5 1.9	1.5 1.9	2.4 3.2	2.4 3.2	4.2 5.6

Note: DC rating available on request.

Moulded Case Circuit Breakers

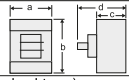
Frame Size [A]	400	400	400	400	630	630	800	800
Type	S400NJ	S400NE	S400GJ	S400GE	S630CE	S630GE	S800NJ	S800NE
Number of Poles	3 4	3 4	3 4	3 4	3 4	3 4	3 4	3 4
■ RATED CURRENT (In) [A] at 40°C	250 400	250 400	250 400	250 400	630	630	630 800	630 800
Rated impulse withstand voltage (Uimp) [kV]	8	8	8	8	8	8	8	8
Rated insulation voltage (Ui) [VAC]	800	800	800	800	800	800	800	800
■ AC RATED BREAKING CAPACITY [kA sym. rms.]								
JIS C 8370	30	30	30	30	30	30	30	30
IEC 60947-2	45	45	65	65	45	65	45	45
EN 60947-2	85	85	100	100	85	100	85	85
lcu/lcs	20/15	20/15	20/15	20/15	20/15*	20/15*	20/20*	20/20*
DC RATED BREAKING CAPACITY [kA] ①	250V	—	40	—	—	—	50	—
Rated short time current (Icw) [kA. rms.]	—	5	—	5	—	—	—	10
Protection	—	—	—	—	—	—	—	—
Adjustable thermal, adjustable magnetic	—	—	—	—	—	—	—	—
Fixed thermal, fixed magnetic	—	—	—	—	—	—	—	—
Microprocessor	—	—	—	—	—	—	—	—
Utilization Category	A	B	A	B	A	A	A	B
■ DIMENSIONS (mm)								
	a 140 185	a 140 185	a 140 185	a 140 185	a 140 185	a 140 185	a 210 280	a 210 280
	b 260	b 260	b 260	b 260	b 260	b 260	b 273	b 273
	c 103	c 103	c 103	c 103	c 103	c 103	c 103	c 103
Weight (kg) (standard type)	4.2 5.6	4.3 5.7	4.2 5.6	4.3 5.7	5.0 6.5	5.0 6.5	8.5 11.5	1* 2*

- * 1) 8.7kg/630A, 9.1kg/800A
- 2) 11.9kg/630A, 12.3kg/800A
- 3) 13.3kg/630A, 14.8kg/800A
- 4) 16.8kg/630A, 18.8kg/800A

* MCCB cannot be used in IT system at this voltage

Moulded Case Circuit Breakers

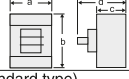
Frame Size [A]	800	1000	1000	1250	1250	1600	1600	
Type	H800NE	S1000SE	S1000NE	S1250NE	S1250GE	S1600SE	S1600NE	
Number of Poles	3 4	3 4	3 4	3 4	3 4	3 4	3 4	
■ RATED CURRENT (In) [A] at 40°C	630 800	1000	1000	1250	1250	1600	1600	
Rated impulse withstand voltage (Uimp) [kV]	8	8	8	8	8	8	8	
Rated insulation voltage (Ui) [VAC]	800	800	800	800	800	800	800	
■ AC RATED BREAKING CAPACITY [kA sym. rms.]								
JIS C 8370	40	30	45	45	65	30	65	
IEC 60947-2	125	45	65	65	85	45	85	
EN 60947-2	150	85	100	100	125	85	125	
lcu/lcs	25/20*	20/15*	25/20*	25/20*	45/34*	20/15*	45/34*	
DC RATED BREAKING CAPACITY [kA] ①	250V	—	—	—	—	—	—	
Rated short time current (Icw) [kA. rms.]	10	—	—	15	15	20	20	
Protection	—	—	—	—	—	—	—	
Adjustable thermal, adjustable magnetic	—	—	—	—	—	—	—	
Fixed thermal, fixed magnetic	—	—	—	—	—	—	—	
Microprocessor	—	—	—	—	—	—	—	
Utilization Category	B	A	A	B	B	B	B	
■ DIMENSIONS (mm)								
	a 210 280	a 210 280	a 210 280	a 210 280	a 210 280	a 210 280	a 210 280	
	b 273	b 273	b 273	b 370	b 370	b 370	b 370	
	c 140	c 103	c 103	c 120	c 120	c 140	c 140	
Weight (kg) (standard type)	3* 4*	11.0 14.8	11.0 14.8	19.8 25.0	19.8 25.0	27.0 35.0	27.0 35.0	

* MCCB cannot be used in IT system at this voltage

Note: DC rating available on request.

DIN MODULAR DEVICES

MCB

SPECIFICATIONS

Rated Current (in)	2, 4, 6, 10, 16, 20, 25, 32, 40, 50, 63, 80, 100, 125A
Rated Capacity	Phase to Neutral 230V/240V~ / Phase to Phase 400V/415V~
Breaking Capacity	6 kA / 10kA
Rigid Conductor	25mm ² Maximum
Flexible Conductor	16mm ² Maximum
Characteristics	B CURVE / C CURVE / D CURVE
Standards	EN 60898 / EN 60947-2 / KEMA / SEMCO / SNI / CE / ROHS
Poles	1, 2, 3 and 4P
Frequency	50/60Hz
Calibration Temperature	30°C
Electrical Endurance	8000
Mechanical Endurance	20000



POLE	In/A	6KA			10KA		
		B curve	C curve	D curve	B curve	C curve	D curve
1	6	EPB06061	EPC06061	EPD06061	EPB10061	EPC10061	EPD10061
	10	EPB06101	EPC06101	EPD06101	EPB10101	EPC10101	EPD10101
	16	EPB06161	EPC06161	EPD06161	EPB10161	EPC10161	EPD10161
	20	EPB06201	EPC06201	EPD06201	EPB10201	EPC10201	EPD10201
	25	EPB06251	EPC06251	EPD06251	EPB10251	EPC10251	EPD10251
	32	EPB06321	EPC06321	EPD06321	EPB10321	EPC10321	EPD10321
	40	EPB06401	EPC06401	EPD06401	EPB10401	EPC10401	EPD10401
	50	EPB06501	EPC06501	EPD06501	EPB10501	EPC10501	EPD10501
	63	EPB06631	EPC06631	EPD06631	EPB10631	EPC10631	EPD10631
	80	EPB06801	EPC06801	EPD06801	EPB10801	EPC10801	EPD10801
	100	EPB061001	EPC061001	EPD061001	EPB101001	EPC101001	EPD101001
	125	EPB061251	EPC061251	EPD061251	EPB101251	EPC101251	EPD101251
2	6	EPB06062	EPC06062	EPD06062	EPB10062	EPC10062	EPD10062
	10	EPB06102	EPC06102	EPD06102	EPB10102	EPC10102	EPD10102
	16	EPB06162	EPC06162	EPD06162	EPB10162	EPC10162	EPD10162
	20	EPB06202	EPC06202	EPD06202	EPB10202	EPC10202	EPD10202
	25	EPB06252	EPC06252	EPD06252	EPB10252	EPC10252	EPD10252
	32	EPB06322	EPC06322	EPD06322	EPB10322	EPC10322	EPD10322
	40	EPB06402	EPC06402	EPD06402	EPB10402	EPC10402	EPD10402
	50	EPB06502	EPC06502	EPD06502	EPB10502	EPC10502	EPD10502
	63	EPB06632	EPC06632	EPD06632	EPB10632	EPC10632	EPD10632
	80	EPB06802	EPC06802	EPD06802	EPB10802	EPC10802	EPD10802
	100	EPB061002	EPC061002	EPD061002	EPB101002	EPC101002	EPD101002
	125	EPB061252	EPC061252	EPD061252	EPB101252	EPC101252	EPD101252
3	6	EPB06063	EPC06063	EPD06063	EPB10063	EPC10063	EPD10063
	10	EPB06103	EPC06103	EPD06103	EPB10103	EPC10103	EPD10103
	16	EPB06163	EPC06163	EPD06163	EPB10163	EPC10163	EPD10163
	20	EPB06203	EPC06203	EPD06203	EPB10203	EPC10203	EPD10203
	25	EPB06253	EPC06253	EPD06253	EPB10253	EPC10253	EPD10253
	32	EPB06323	EPC06323	EPD06323	EPB10323	EPC10323	EPD10323
	40	EPB06403	EPC06403	EPD06403	EPB10403	EPC10403	EPD10403
	50	EPB06503	EPC06503	EPD06503	EPB10503	EPC10503	EPD10503
	63	EPB06633	EPC06633	EPD06633	EPB10633	EPC10633	EPD10633
	80	EPB06803	EPC06803	EPD06803	EPB10803	EPC10803	EPD10803
	100	EPB061003	EPC061003	EPD061003	EPB101003	EPC101003	EPD101003
	125	EPB061253	EPC061253	EPD061253	EPB101253	EPC101253	EPD101253

DIN MODULAR DEVICES

RCCB

SPECIFICATIONS

Rated Capacity	25 A, 32 A, 40 A, 63 A, 80 A, 100 A
Rigid / Flexible Conductor	35mm ² / 25mm ² MAXIMUM
Calibration Temperature	30°C
Frequency	50/60Hz
Electrical Endurance	10000
Mechanical Endurance	20000
Standards	EN 61008-1 / EN 61008-2-1 / ROHS / CE
Poles	2P and 4P; Ue: 230 Vac (2P), 230/400 Vac (4P); 50/60 Hz;
I Δ n	10 mA, 30 mA, 100 mA, 300 mA, type A and AC;
I Δ c = I Δ c	6 kA; I Δ m = I Δ m: 10 I Δ n or 500 A whichever is the greater;



Sensitivity	Current	Cat. Ref	Cat. Ref
I Δ n		2 poles	4 poles
10mA	16A	EPR2016010AC	EPR4016010AC
	20A	EPR2020010AC	EPR4020010AC
	25A	EPR2025010AC	EPR4025010AC
	32A	EPR2032010AC	EPR4032010AC
30mA	16A	EPR2016030AC	EPR4016030AC
	25A	EPR2025030AC	EPR4025030AC
	32A	EPR2032030AC	EPR4032030AC
	40A	EPR2040030AC	EPR4040030AC
	63A	EPR2063030AC	EPR4063030AC
	80A	EPR2080030AC	EPR4080030AC
100mA	100A	EPR2100030AC	EPR4100030AC
	16A	EPR2016100AC	EPR4016100AC
	25A	EPR2025100AC	EPR4025100AC
	32A	EPR2032100AC	EPR4032100AC
	40A	EPR2040100AC	EPR4040100AC
	63A	EPR2063100AC	EPR4063100AC
	80A	EPR2080100AC	EPR4080100AC
300mA	100A	EPR2100100AC	EPR4100100AC
	16A	EPR2016300AC	EPR4016300AC
	25A	EPR2025300AC	EPR4025300AC
	32A	EPR2032300AC	EPR4032300AC
	40A	EPR2040300AC	EPR4040300AC
	63A	EPR2063300AC	EPR4063300AC
	80A	EPR2080300AC	EPR4080300AC
	100A	EPR2100300AC	EPR4100300AC

RCBO

SPECIFICATIONS

In accordance with: IEC 61009	Rated voltage: 230VAC
Certification: CE, SEMKO	Rated residual operating current I Δ n : 10mA, 30mA, 100mA, 300mA
Pole composition: 2P	Residual tripping current range: 0.5 I Δ n ~ 1I Δ n
Residual current characteristics: AC	Electrical lifetime > 4,000 cycles
Tripping curve: C	Fastening torque: 2.0Nm
Calibration temperature: +30°C	Terminal capacity: 35mm ² solid, 25mm ² stranded conductor
Rated current: 16A, 20A, 25A, 32A, 40A	Mounting on rail EN 60715 (EN 50022)
Rated short circuit capacity: 6 kA	Operating temperature: -25°C ~ +55°C
Rated frequency: 50/60Hz	

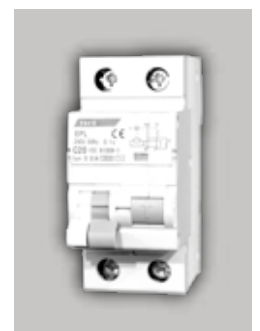

RTR POWER CAPACITORS - 440Vac

Model (Order code)	Voltage (V)	Frequency (Hz)	Power (KVAR)	Diameter (mm)	Height (mm)
C440 - 0255 - TER	440	50	2.5	70	215
C440 - 0505 - TER	440	50	5	70	215
D440 - 1005 - DW	440	50	10	70	230
D440 - 1255 - DW	440	50	12.5	85	230
D440 - 1505 - DW	440	50	15	85	230
D440 - 2005 - DW	440	50	20	100	230
D440 - 2505 - DW	440	50	25	120	230
D440 - 3005 - DW	440	50	30	120	230
D440 - 4005 - DW	440	50	40	136	230
C440 - 5005 - TER	440	50	50	136	300

RTR POWER CAPACITORS - 525Vac

Model (Order code)	Voltage (V)	Frequency (Hz)	Power (KVAR)	Diameter (mm)	Height (mm)
D525- 1005 - DW	525	50	10	85	230
D525 - 1250 - DW	525	50	12.5	85	230
D525 - 1505 - DW	525	50	15	100	230
D525 - 2005 - DW	525	50	20	120	230
D525 - 2005 - DW	525	50	25	120	230
D525 - 3505 - DW	525	50	30	136	230
D525 - 3505 - DW	525	50	35	136	230
D525-5000--TER	525	50	50	136	300

Characteristics and utility

- Three phase capacitor DUAL WINDING internally delta connected
- Discharge resistors Incorporated
- Reactive power factor correction
- Dry type
- Connector type terminal
- Indoor mounting

Triple safety

- Overpressure disconnection system
- Protection by internal fuses
- DWCAP system (patent) internal windings Displacement

Construction and materials

- Low losses metallized self-healing polypropylene film, high density, high temperature and greater dielectric resistance Volt/ μ
- Polyurethane self-extinguishing resin V0, developed under standard UL 94 by RTR Energia
- Aluminium case with botton fixing M12x16

Standards

- IEC 60831-1/2
- EN 60831-1/2

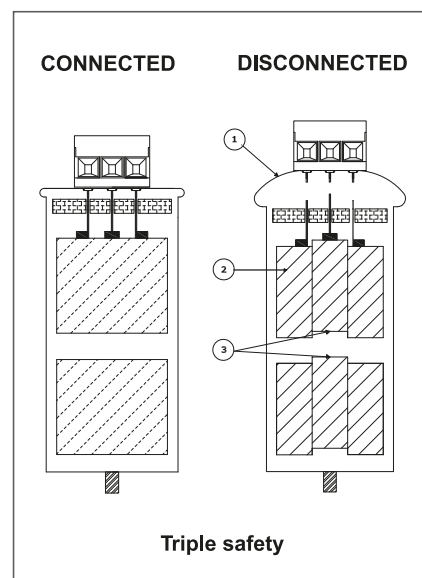

DETUNED REACTOR

525V Capacitor - Filter 415V -7% - 189Hz Copper

525V / kVAR	Filter / kVAR	Load Ampere	Inductance mH	Capacitor μ F
5	3.35	4.7	12.32	3x19.19
7.5	5.03	7	8.2	3x28.82
10	6.71	9.3	6.15	3x38.44
12.5	8.39	11.7	4.92	3x48.07
15	10.06	14	4.1	3x57.64
20	13.42	18.7	3.07	3x76.89
25	16.79	23.4	2.46	3x96.2
30	20.13	28	2.05	3x115.33
40	26.85	37.4	1.54	3x153.84
50	33.55	46.7	1.23	3x192.22
75	50.33	70	0.82	3x288.37
100	67.20	93.5	0.61	3x385.02

525V Capacitor - Filter 415V -7% - 189Hz Aluminium

525V / kVAR	Filter / kVAR	Load Ampere	Inductance mH	Capacitor μ F
5	3.35	4.7	12.32	3x19.19
7.5	5.03	7	8.2	3x28.82
10	6.71	9.3	6.15	3x38.44
12.5	8.39	11.7	4.92	3x48.07
15	10.06	14	4.1	3x57.64
20	13.42	18.7	3.07	3x76.89
25	16.79	23.4	2.46	3x96.2
30	20.13	28	2.05	3x115.33
40	26.85	37.4	1.54	3x153.84
50	33.55	46.7	1.23	3x192.22
75	50.33	70	0.82	3x288.37
100	67.20	93.5	0.61	3x385.02

Three Phase Harmonic Filters

Three Phase Harmonic Filters are made of low losses magnetic plates and copper winding.

Compliances Standard	IEC-60289, IEC - 076
Tolerance 'L'	3%
Permissible Overload	1.07 In
Linearity Inductance	1.501 In
Heat Insulation	Class H (180°C)
Thermal Protection	120°C
Room Temperature	45°C
Prof. Stress	3 KV
Protection Degree	IP - 00



Ratings of Relays

Type	
Phase and wires	3φ3W, 1φ2W
Outside view	3φ4W

RATINGS

Rated control voltage [VAC]	50/60Hz
Applicable range	120V AC 240V AC
Rated sensitivity current [mA]	30 100 300 ③ 500 1000

Rated operating time (sec)	below 0.04 0.3 0.5 ③④ 1 2
----------------------------	---------------------------------------

Dimensions [mm] (surface mount) W/H/D	60/78/100
Weight [kg] (surface mount)	0.22

MOUNTING

Surface mount
Flush mount

STANDARD FEATURES

Earth leakage detection	③
Output contact	1C ⑥
Earth leakage indication	LED (Red)
Reset function	electrical ⑦
Power source required	1VA

TZS-AD



120 ①②
240
96-132
192-264
30
100
300 ③
500
1000
below 0.04
0.3
0.5 ③④
1
2
60/78/100
0.22
●
•
③
1C ⑥
LED (Red)
electrical ⑦
1VA

Connection Diagram

• Earth Leakage Relay

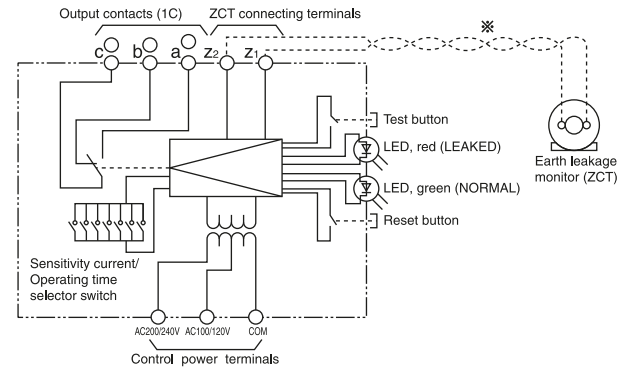

※ TZS-AD — ZCT wire length

30mA : less than 3m, 100, 300 mA : less than 5m, 500, 1000 mA : less than 10m

Note : The output contacts are hold until the reset button is pressed.

Loss of control power resets the contacts automatically.

Terminal screw tightening torque: 0.45-0.73 N.m

- Note**
- : Standard, this configuration is used unless otherwise specified.
 - : yes" or "available".
 - ① : Terminals for 120V AC and 240V AC are provided.

CAUTION : DO NOT APPLY 240V AC TO THE 120V AC TERMINAL. BURNOUT CAN RESULT.

- ② : For 415V AC or 440V AC, Please contact to TERASAKI.
- ③ : Adjustable type by Dip slide switch.
- ④ : Operating time range and Non-operating time range.

Rated operating time (sec)	Operating time range (sec)	Non-operating time range (sec)
0.3	0.2-0.36	0.15
0.5	0.4-0.6	0.38
1	0.8-1.2	0.7
2	1.3-2	1.25

- ⑤ : Solid-state type, current operating type.
- ⑥ : Ratings of output contact.

	Resistance load cos φ = 1	Inductive load cos φ=0.4 (L/R=7ms)	Min. load
120V AC	6A	3.5A	10mA at 5V DC
240V AC	6A	3.5A	
30V DC	6A	3A	

- ⑦ : The output contacts remain until the RESET button is operated.
Provided the control power supply fails the contacts automatically reset.

Ratings of ZCT (Core Balanced Current Transformers)

Type
Outside view

Diameter of transit part [mm]	
Weight [kg]	
Applicable numbers, size and continuous current of wires (IV cable wires)	
2 wires	max. continuous current max. wires size max. diameter of wire
3 wires	max. continuous current max. wire size max. diameter of wire
4 wires	max. continuous current max. wire size max. diameter of wire

TZS-15

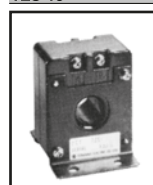

ø15
0.2
61A
8mm ²
6mm
61A
8mm ²
6mm
49A
5.5mm ²
5mm

TZS-24



ø24
0.3
139A
30mm ²
10.5mm
139A
30mm ²
10.5mm
115A
22mm ²
9.5mm

TZS-40

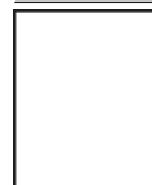

ø40
0.7
298A
100mm ²
17mm
298A
100mm ²
17mm
257A
80mm ²
15.5mm

TZS-68

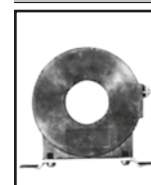

ø68
1.1
650A
325mm ²
29mm
650A
325mm ²
29mm
556A
250mm ²
26mm

TZS-100



ø100
2.0
1185A
850mm ²
45mm
1185A
850mm ²
45mm
992A
600mm ²
38mm

Appearance of major products

TemPower

Air Circuit Breakers with enhanced OCR



TemBreak

Moulded Case Circuit Breakers



Air Circuit Breakers (AME series for Generator Protection)



Earth-leakage Relays



TECS

DIN MODULAR DEVICES
MCB / RCCB / RCBO



RTR
energia



 CAUTION

Be sure to read the instruction manual carefully
to ensure correct and safe use of the product.

 **TERASAKI OVERSEAS NETWORK**

TERASAKI ELECTRIC (M) SDN. BHD.

Lot 3, Jalan 16/13D, 40000 Shah Alam, Selangor Darul Ehsan, MALAYSIA
Telephone : 60-3-5549-3820 Fax : 60-3-5549-3960 / 60-3-5512-9299
E-mail : terasaki@terasaki.com.my
Central : ykkoh@terasaki.com.my Mobile No : +6-019-211 9948
Northern : eng@terasaki.com.my Mobile No : +6-019-323 0777
Southern : erictang@terasaki.com.my Mobile No : +6-016-773 3828

**TERASAKI ELECTRIC TRADING &
SERVICES (M) SDN. BHD.**

No. 20 & 22, Jalan Rajawali 2, Bandar Puchong Jaya,
47100 Puchong, Selangor Darul Ehsan, MALAYSIA

Telephone : 60-3-8075-1542
Fax : 60-3-8070-2481

TERASAKI (EUROPE) LTD.

80 Beardmore Way, Clydebank Industrial Estate, Clydebank, Glasgow, G81 4HT. SCOTLAND (U.K.)
Telephone : 44-141-941-1940 / Fax : 44-141-952-9246
E-mail : marketing@terasaki.co.uk
<http://www.terasaki.com/>

TERASAKI ITALIA s.r.l.

Via Ambrosoli 4A-20090 Rodano, Milano, ITALY
Telephone : 39-02-92278300 / Fax : 39-02-92278320
E-mail : info@terasaki.it
<http://www.terasaki.it/>

TERASAKI ESPAÑA, S.A.U.

Roma, s/n, 08400 Granollers, Barcelona, SPAIN
Telephone : 34-93-879-60-50 / Fax : 34-93-870-39-05
E-mail : terasaki@terasaki.es
<http://www.terasaki.es/>

TERASAKI SKANDINAVISKA AB

Fräsarvägen 32, SE-142 50 Skogås SWEDEN
Telephone : 46-8-556-282-30 / Fax : 46-8-556-282-39
E-mail : info@terasaki.se
<http://www.terasaki.se/>

TERASAKI CIRCUIT BREAKERS (S) PTE. LTD.

9 Toh Guan Road East 03-01 Alliance Building, Singapore 608604, SINGAPORE
Telephone : 65-6425-4915 / Fax : 65-6425-4351
E-mail : teecs@pacific.net.sg

TERASAKI DO BRASIL LTDA.

Rua Cordovil, 259-Parada De Lucas, 21250-450 Rio De Janeiro-R. J., BRAZIL
Telephone : 55-21-3301-9898 / Fax : 55-21-3301-9861
E-mail : terasaki@terasaki.com.br
<http://www.terasaki.com.br/>

TERASAKI ELECTRIC (CHINA) LTD.

72 Pacific Industrial Park, Xing Tang Zengcheng, Guangzhou 511340, CHINA
Telephone : 86-20-8270-8556 / Fax : 86-20-8270-8586
E-mail : terasaki@public.guangzhuo.gd.cn

TERASAKI ELECTRIC GROUP SHANGHAI REPRESENTATIVE OFFICE

Room No. 1405-6, Tomson Commercial Building, 710 Dong Fang Road, Pudong, Shanghai, 200122, CHINA
Telephone: 86-21-58201611 / Fax : 86-21-58201621
E-mail : terasaki@vip.163.com

 **TERASAKI ELECTRIC CO., LTD.**

Head Office: 7-2-10 Hannancho, Abenoku, Osaka, JAPAN
Circuit Breaker Division : 7-2-10 Kamihigashi, Hiranoku, Osaka, JAPAN
Telephone : 81-6-6791-9323 / Fax : 81-6-6791-9274
E-mail : int-sales@terasaki.co.jp
<http://www.terasaki.co.jp/>